

The Next Generation of Portable Displays



Tradeshows Just Got a Whole Lot Easier!



From 0 to Set-up in 60 Seconds.

Imagine... A freestanding display that weighs only 12 lbs. and sets up in less than 60 seconds.

Introducing the ShowFlex, the newest innovation from EXPOGO, creators of the ShowStyle Briefcase and ShowMax Self-packing Tabletop Displays.

With its innovative design and vibrant dye-sub graphics, ShowFlex may be the lightest weight, easiest to set up display system around.

Available in a kaleidoscope of sizes and shapes, there is a ShowFlex for any display or presentation need.

The ShowFlex patent-pending, "Butterfly Hub" and folding frame design eliminates the need for bulky pop-ups that are expensive to ship, or tension fabric units with separate graphics to install each time you set up. Simply stand the ShowFlex upright on a table, unfold the hinged arms, extend the telescoping leg and you are ready to show!

"Walk in with ShowFlex and watch great things unfold at your next event".



ShowFlex™ Umbrella Display

A Series/Recruiter



B Series/Presenter

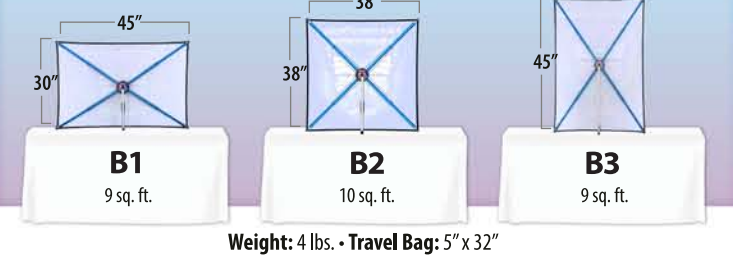

C Series/Exhibitor



D Series/Carry-On



E Series/Ultra-Compact

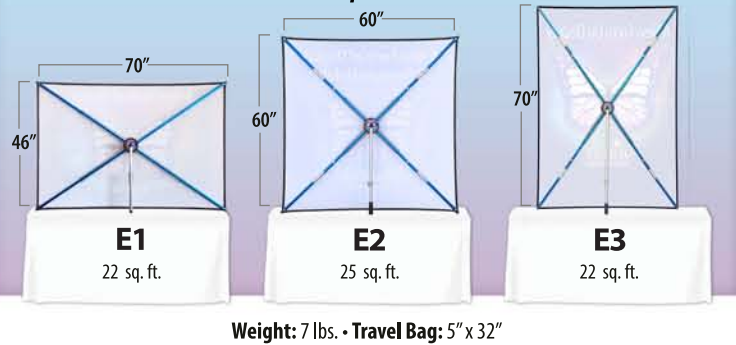

F Series/Freestanding

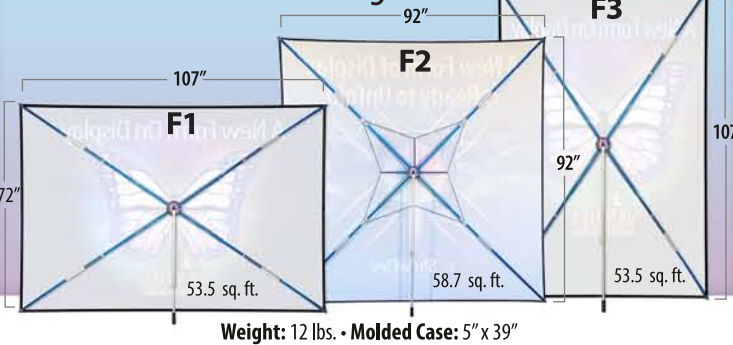

G Series

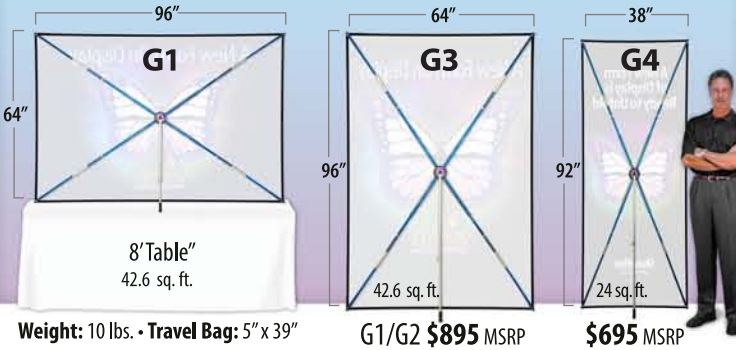

F Series/96" or 107" tall center



Series A	Series B	Series C	Series D	Series E	Series F
A1 - A3	B1 - B3	C1 - C3	D1 - D3	E1 - E3	F1 - F3
\$325	\$435	\$575	\$695	\$795	\$1,325

All ShowFlex units include dye-sub graphics.



F-Series freestanding units include molded banner case. Dye-sub graphics printed on 100% polyester knit fabric.

ShowFlex™ HexFrame

HexFrame Tabletops

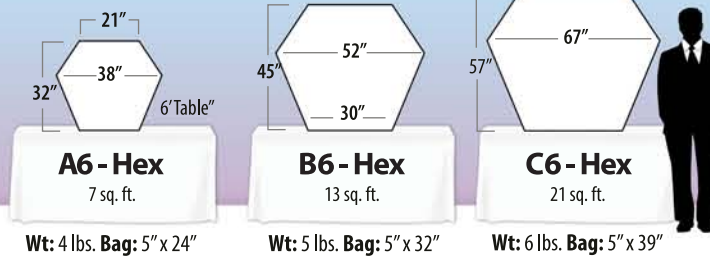

HexFrame Trio



F6 HexFrame

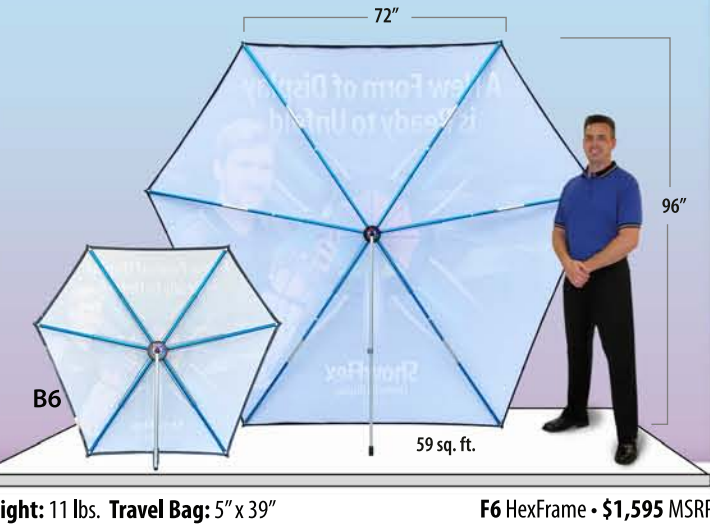

F6 HexFrame Trio 10'

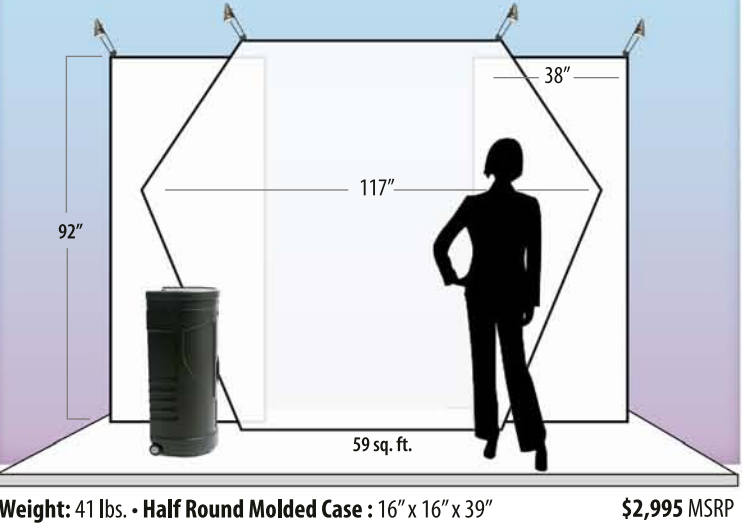

F6 HexFrame Trio 20'

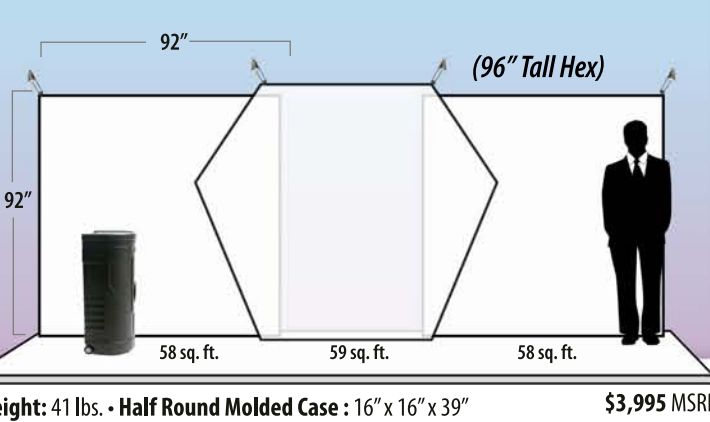

F6 HexFrame Trio 20'

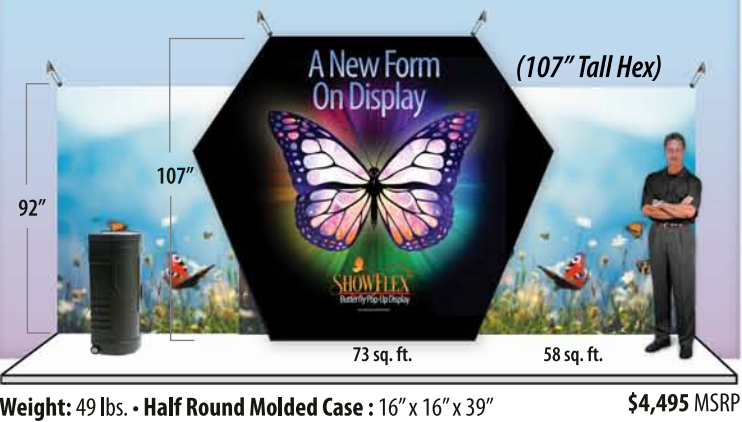

LumaStar BatteryPack



HexFrame Series Pricing

A6 Hex	B6 Hex	C6 Hex	A6 Trio	B6 Trio	C6 Trio
36" x 32"	52" x 45"	67" x 57"	57" wide	72" wide	96" wide
\$425	\$575	\$795	\$995	\$1,295	\$1,795

Optional LED Lights. \$95 ea. MSRP

All ShowFlex units include graphics printed on 100% polyester knit fabric.

Self-Packing Tabletop Displays



Open Size: 24" x 48" • Wt. 10 lbs.

ShowStyle® Briefcase Display

ShowStyle opens in seconds with graphics attached and ready to show. Includes an arched header that stores in the back of the display.



An Open & Shut Case for Success!

ShowStyle Briefcase
\$295 MSRP
Graphics not included.



US Patent #6,189,594
CAN Patent #2,306,358



Open Size: 32" x 64" • Wt. 20 lbs.

Pro32® Briefcase Display

The ShowStyle Pro32 has 14 sq. ft. of graphic area, 77% more than original the ShowStyle. Features a retractable handle and velcro-ready fabric to attach graphics that remain in place for transport.



Optional LED Lights

Pro32 Tabletop
\$545 MSRP
Graphics not included.



Open Size: 36" x 72" • Wt. 39 lbs.

ShowMax® Self-packing Tabletop

The ShowMax Self-Packing Tabletop features a retractable handle, inline skate wheels, an arched header and two LED lights that store in the back of the display.



Includes Two LED Lights

ShowMax Tabletop
\$995 MSRP
Graphics not included.

US Patent #6,772,816 B2



Fabric & Rollable Graphic Pop-Ups

Curved or straight freestanding pop-up displays are available with rollable graphic panels, or with vibrant dye-sub fabric that remains attached for quick set-up.



Tension Fabric Displays

Tension fabric "pillowcase" style displays can be printed with single or double-sided fabric graphics. Back-lit fabric pop-up or Silicon Edge (SEG) displays stand out on the busy trade show floor.



Back-lit Displays



20' Serpentine Pop-up

Multiple curved and straight pop-up frames can be used to create a wide variety of configurations. Add custom printed carpet and counters for a more custom look.

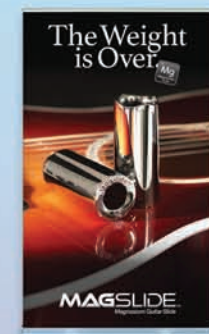

Bannerstands

Bannerstands and feather flags are a great way to call attention to your business or event. Both are available in a variety of sizes and shapes, with either single or double sided graphics.



Feather Flags

As Simple to Use as an Umbrella.

ShowFlex represents a new category of portable displays,
and may be the lightest weight, easiest to set-up
display system around.

As simple to use as an umbrella, the new
patent-pending ShowFlex opens and
closes in seconds, with the
graphics already attached
and ready to show!



Display Solutions Inc.
800-292-4925
DisplaySolutionsStore.com

©2012 Display Solutions Inc.